

TOYOTA

TOYOTA MATERIAL HANDLING INDIA

 **TOYOTA**
MATERIAL HANDLING

Safety is Utmost Priority

ACCESSORY CATALOGUE



1. Camera System

The Camera System is an excellent tool to enhance operator visibility around the lift truck. It can be installed as per the requirement/application (front side or back side of the lift truck), where visibility is limited .

1.1 Fork camera system

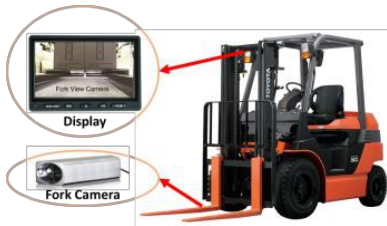

- IP Rating - IP69
- Suitable for cold storage application
- High shock and vibration resistance
- Easy to install

1.2 Carriage camera system

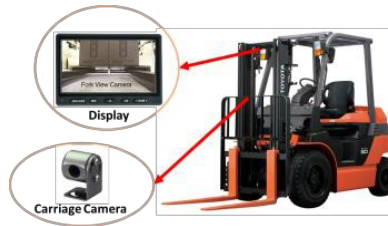

- State-of-the-art image electronics
- High shock and vibration resistance
- High sensitivity to light
- Sharp and high-contrast images
- Highest protection class IP69K
- Easy to install

1.3 Rear/Front (Dual) view camera



- Line of Sight range ≤ 50 meter
- Free viewing angle 45 Degree
- IP Rating - IP68/IP69
- Operating temperature -20° C to +70° C

2. LED Beacon Light & Buzzer

LED Beacon & Buzzer system play a big part in pedestrian safety by providing visible and acoustic alarm to pedestrian. It is a good tool to avoid accidents and create a safe working environment.

2.1 Beacon Light

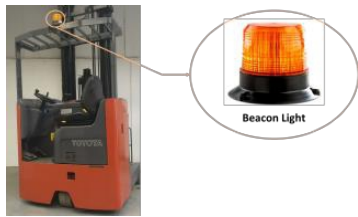

- Heavy duty metal housing
- IP Rating - IP69K
- Resistance to low temperature

2.2 Buzzer system



- Designed as per SAE standards
- Sound Level Range – 107 ~ 112 dB

2.3 Beacon with Buzzer



- Operating temperature -25° C to +70° C
- Heavy duty metal housing
- Maximum sound Level – 120dB

3. LED Lights

3.1 Standard LED Work light



- 20-Watt High performance universal LED light
- 100-Watt Halogen Compatible Fixture
- Reduced power draw can lead to energy savings

3.2 Multi Function LED light



- LED Head lamp with turn Indicator

4. Laser Marker (Fork Alignment)

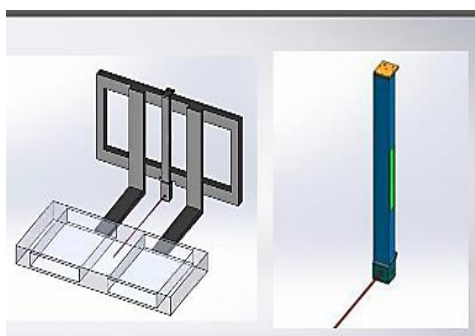

The Laser marker system provides added accuracy and safety. It aligns forks with pallet fork slots to prevent damage to goods/load.

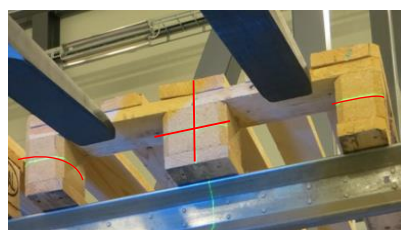

- Bright enough & easily visible
- Long life span
- Easy to install

5. Pedestrian Safety Spot light

Solution that minimizes any risks of collisions between forklifts and pedestrian in common work areas

5.1 Red/ Blue Spot Light



- Easy to install
- IP rating- IP68/IP69
- Light Output: 750 Lumens

This red/blue light project a bright red/blue spot on the floor which warns pedestrians about forklifts approaching from blind corners.

5.2 Arc Light



- Color: Red or Green
- IP Rating: IP67
- Easy to install
- Working Temperature: -45 to 85°C
- Long life span

5.3 Arrow light



- Blue or Red arrow projection
- Aluminum heatsink housing
- Polycarbonate lens

5.4 Red/Blue Zone Light



To ensure pedestrians stay at safe distance from forklift.

- Color: Red or Blue
- IP Rating: IP67
- Working Temperature: -45 to 85°C
- Long life span

6. TYE-Site



TYE-Site is a fleet management solution to increase safety, reduce cost and improve productivity with reports provided for analysis with regular advice and support

7. Pedestrian Safety System

7.1 Reverse Anti-Collision Sensor with/without Camera



It's a collision avoidance system for forklift which detects potential obstacles in operational work area.

- Active maneuvering system
- Adjustable sensing range



7.2 Over Speed Alarm

It monitors vehicle speed and warns when a predetermined speed set by driver has been exceeded.

- Making the driver aware of excessive speed.
- Audio and visual alarm

8. Accessories

8.1 Universal battery Lifting tool



This tool enables easy removal of batteries

- Safer than lifting batteries with chain or belt
- Chain length can be adjusted

8.2 Biometric Device



It Can be used on all types of material handling equipment

- Easy to register new users
- Up to 500 user access
- Easy to retrieve data

8.3 Operator Cabin Fan



- 12 Volt with 4 wing plastic blade fan
- Single toggle switch

8.4 Safety Seat Belt



- Seatbelt With Interlock system
- Applicable from 10 to 80 Volts
- Neon Orange color for utmost visibility

8.5 Spark Guard Net



The spark guard net fits on the end of the exhaust pipe and prevents sparks from leaving the exhaust system.

- The metal nets collect and destroy large carbon particles

APPLICABLE MODEL LIST

SN	ITEM	APPLICABLE MODELS						
		Diesel Forklift	Battery Forklift (4 wheel)	Battery Forklift (3 wheel)	BOPT	Stacker	Reach Truch	OTHERS
								
1.1	Fork Camera System	✓	✓	✓			✓	
1.2	Carriage Camera System	✓	✓	✓			✓	VRE, 8RFBA
1.3	Rear/Front Dual View Camera	✓	✓	✓				
2.1	Beacon Light	✓	✓	✓		✓	✓	
2.2	Buzzer System	✓	✓	✓		✓	✓	Order Pickers, VRE, 8RFBA
2.3	Beacon With Buzzer	✓	✓	✓			✓	Order Pickers, VRE, 8RFBA
3.1	Standard LED Work light	✓	✓	✓			✓	Order Pickers, VRE, 8RFBA
3.2	Multifunctional Led Light With Indacator	✓	✓	✓			✓	Order Pickers, VRE, 8RFBA
4	Laser Marker(Fork Alignment)	✓	✓	✓			✓	
5.1	Red / Blue Spot Light	✓	✓	✓		✓	✓	Order Pickers
5.2	ARC Light	✓	✓	✓			✓	Order Pickers
5.3	Arrow Light	✓	✓	✓		✓	✓	Order Pickers
5.4	Red/Blue Zone Light	✓	✓	✓			✓	Order Pickers
6	TYE-Site	✓*	✓	✓				
7.1	Reverse Anti-Collision Sensor With/Without Camera	✓	✓	✓				
7.2	Over Speed Alarm	✓						
8.1	Universal Battery Lifting Tool		✓	✓	✓	✓	✓	
8.2	Biometric Device	✓	✓	✓			✓	
8.3	Operator Cabin Fan	✓	✓	✓			✓	
8.4	Seat Belt Interlock	✓	✓	✓			✓	
8.5	Spark Guard Net	✓**						

✓* Applicable for all diesel model except FD30H.

✓** Applicable only for FDZN20,25,30 & 8FD20,25,30,35

Toyota Material Handling India Pvt. Ltd.

Head Office: 43 Milestone NH-8, Delhi-Jaipur Highway, Gurgaon – 122004, Haryana

Tel: 0124-3877100, E-mail: info.sales@tmhin.toyota-industries.com, Web: www.toyotamaterialhandlingindia.com

For Enquiries

Bangalore M: +91-9845003971

Delhi M: +91-9810997357

Mumbai M: +91-9004415045

Hyderabad M: +91-9100878731

Kolkata M: +91-9883240930

Pune M: +91-9075028750

Chennai M: +91-9600986222

Chandigarh M: +91-9417413541

Ahmedabad M: +91-8600239978

Coimbatore M: +91-9600954666

TOYOTA

TOYOTA MATERIAL HANDLING INDIA

TOLL FREE NUMBER
1800-300-000-75