

Flexible Travel Control Boosts Work Efficiency, Saves Space for Carrying Lengthy Loads.

Travel Modes

A diverse range of travel modes can be selected by the simple switch operation.



Mode Selecting Switches

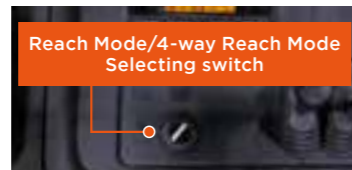

To match the usage conditions, 8FBS can be switched to the reach mode, which provides the same travel feeling as reach trucks.

Sideways Travel Mode

This mode enables sideways travel for carrying lengthy items through narrow aisles.

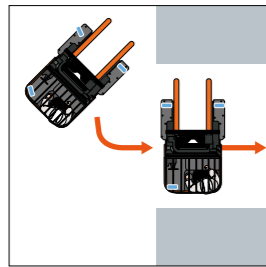

Space Savings

By traveling sideways, even the truck with lengthy load can move through narrow aisle close to the vehicle length.

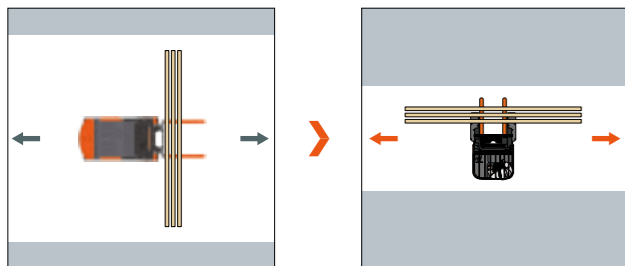

Counterbalanced forklift

8FBS(Sideways travel mode)

4-way Acceleration Lever

For sideways travel, operating the lever to the left or right moves the truck to the left or right. It enables intuitive travel operation.

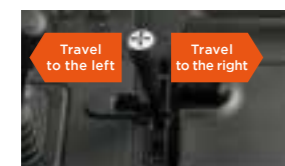

Right Angle Turn Mode

Truck can make right angle turn in narrow aisles, by controlling the center of turning to be on the side of the truck.

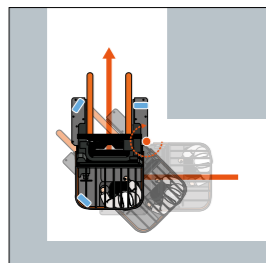

360 Rotation Mode

The center point for turning becomes close to the center of vehicle, enabling smaller turning radius than reach trucks.

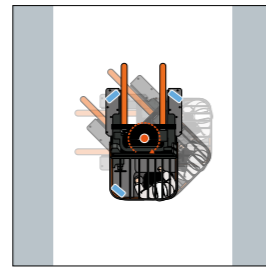

Small Turning Radius.

1,225mm

Note: 1.5 ton model (360 rotation mode)

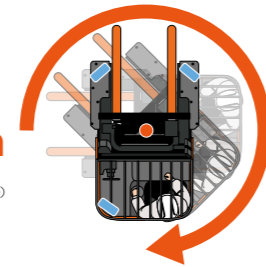

Compact Body

The compact overall width contributes to even greater space savings.

Overall width

1,240mm

Note: 1.5 ton model



Parallel Travel Mode

Truck can travel parallel way to all directions. This makes it easy to adjust the position when approaching a rack with lengthy load.

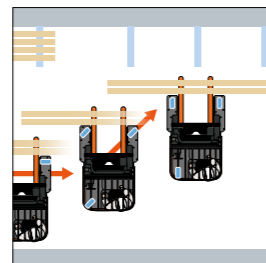

Main Specifications

Model	Standard Type						High-mast Type	
	8FBS10	8FBS13	8FBS15	8FBS18	8FBS20	8FBS25	8FBSS20	8FBSS25
Operation Position	Stand-up	Stand-up	Stand-up	Stand-up	Stand-up	Stand-up	Stand-up	Stand-up
Load Capacity	kg 1,000	1,250	1,500	1,800	2,000	2,500	2,000	2,500
Load Center	mm 500	500	500	500	500	500	500	500
Overall Width	A mm 1,240	1,240	1,240	1,240	1,365	1,365	1,365	1,365
Turning Radius (Outside)* B	mm 1,185	1,185	1,225	1,225	1,270	1,285	1,270	1,285
Overhead Guard Height C	mm 2,250	2,250	2,250	2,250	2,330	2,330	2,330	2,330
Length to Fork Face D	mm 1,050	1,050	1,155	1,155	1,250	1,270	1,250	1,270

* 360 rotation mode

Standard Type



8FBS15



8FBS25

No capacity reduction at lift height of 4m

High-mast Type

High-mast type is suitable for worksites need higher load stacking

Smaller capacity reduction at high lift height enables stable high-stacking operations, supporting effective use of space.

Note: the SV4000 mast is standard on the high-mast type.

No capacity reduction at lift height of 5m

Battery and Motor Specifications

Model			8FBS10	8FBS13	8FBS15	8FBS18	8FBS20	8FBS25	8FBSS20	8FBSS25
	Voltage/Capacity (5-hour ratings)	Min	V/AH	48/201	48/201	48/280	48/280	48/320	48/320	48/320
Max		V/AH	48/240	48/240	48/370	48/370	48/445	48/445	48/445	48/445
Electric Motors	Drive	kW	4.9	4.9	4.9	4.9	5.2	5.2	5.2	5.2
	Load Handling	kW	8	8	8	8	11	11	11	11
	Power Steering	kW	0.26	0.26	0.26	0.26	0.35	0.35	0.35	0.35

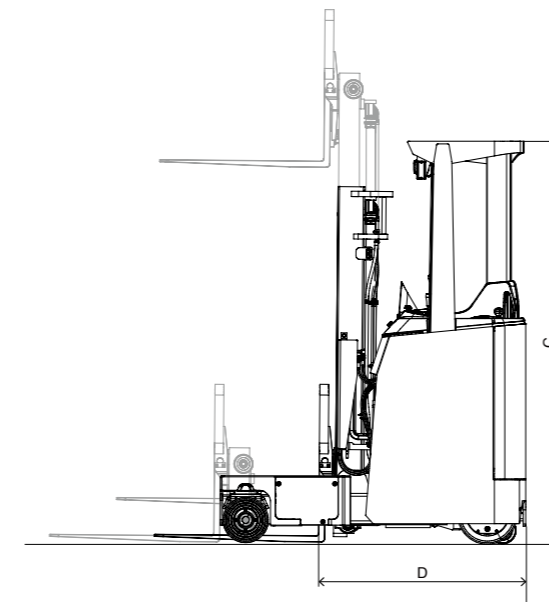
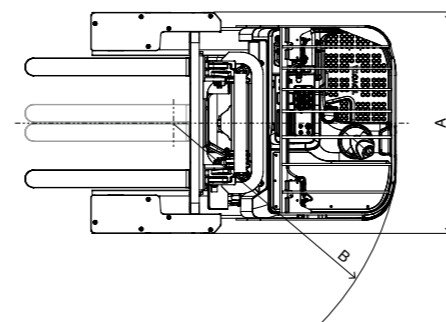

OPS does not operate the brakes. Always set the parking brake before leaving the forklift. Travel OPS is not available on manual transmission models.

The data in this leaflet is determined based on our standard testing condition.

The performance may vary depending on the actual specification and condition of the vehicle as well as the condition of the operating area.

Availability and specifications depend on market and are subject to change without notice.

Due to photography and printing, color of actual vehicle may vary from this leaflet. Some photos have been computer-enhanced. Please consult your Toyota representative for details.



Website



YouTube

All rights reserved by Toyota Industries Corporation.



TOYOTA MATERIAL HANDLING INTERNATIONAL
CAT.8FBS10-25(E)/2209(S)/Printed in Japan/No.711570E0/500

8FBS

SERIES



Get Full Control to All Directions.



Outstanding tight-turn performance for superior operability in narrow space.



Sideways travel mode needs very small space to handle long loads.

Long Operating Time & Long Battery Life

Long Operating Time

Features that include new highly-efficient AC motors and motor-drivers, and regenerative systems that recover energy to the battery, achieve long operating time.

1.0t operating time	10 ^h 45 ^{min}	48V 280AH/5h
2.5t operating time	8 ^h 05 ^{min}	48V 320AH/5h

Note: Continuous operating time based on Toyota operating cycle at S mode. Operating time may vary according to customer usage conditions.

Smart Charging System

*Only for on-truck charger

The motors and motor drivers are used to control the charging current according to the battery condition (voltage, fluid temperature, and deterioration state). This lessens battery damage and contributes less battery fluid reduction.

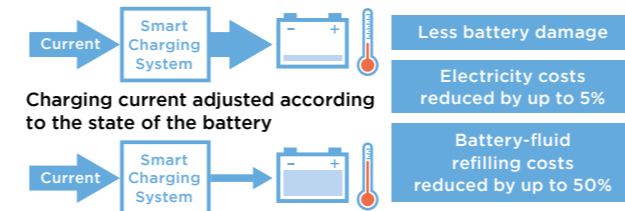

Note: May vary according to customer usage conditions.

Battery Protecting Function

When the battery fluid level is low or the fluid temperature is high, this informs the operator by an indicator and audible warning, and also restricts travel performance. This helps prevent degradation of the battery and ensure a long life for the battery.

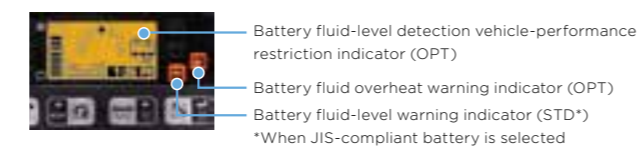

Easy Operation

Operator's Compartment



- 1 Back support with integrated assist grip
- 2 Assist grip
- 3 Pencil holder
- 4 Cup holder
- 5 Spacious flat top panel
- 6 Small-diameter steering wheel
- 7 Hand protector

Easy Entry and Exit

The left and right assist grips and low floor height make getting on and off more smooth.

Floor Height

1 ton series	250mm
2 ton series	315mm

Floor height (1 ton series): 250mm

Panoramic Mirror

The curved-surface mirror provides broad view of operator's back side.

Safety

Rear-positioned Headguard Pillar

The headguard pillar located at the rear ensures outstanding forward visibility. This design also contributes to support and protect operator's back.



Shockless Landing

The speed of fork lowering automatically slows down just before contacting the ground, contributing to reduce the noise.

Automatic Turn-speed Control

Turn speed is controlled according to the lift height, load weight, and turning radius, providing stable turning matched to the state of operation.

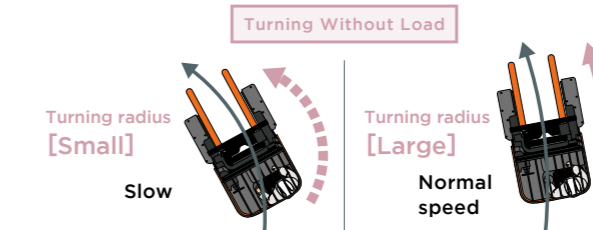

Vehicle speed adjusted according to turning radius

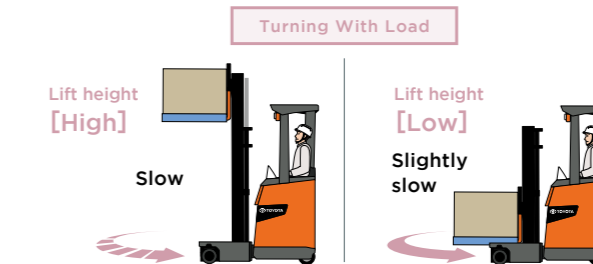

Vehicle speed adjusted according to turning radius, load weight and lift height.

LED Blue Light

A blue spot light appears on the ground to inform pedestrians of the forklift's presence, and helps prevent accidents.

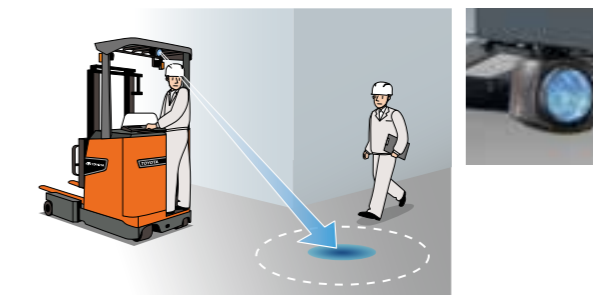

Anti-rollback

When the acceleration lever is released on a grade, the forklift stops for a while and then descends at a constant speed. This helps to ensure smooth operation on slopes.



Load Weight Indicator

When lifting operation is stopped, the load weight is shown on the display. This helps to prevent overload.



Note: This cannot be used for commercial transactions.

Maintenance

Battery Reach Out System

The battery can be reached out easily. It enables smooth battery maintenance, inspection, and replacement.

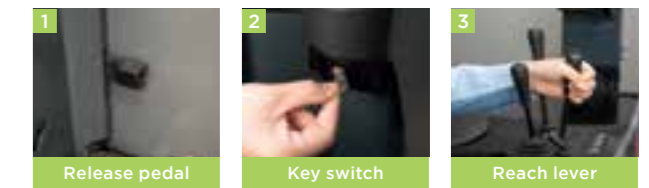

To prevent unintentional operation, battery is reached out only when 1, 2, and 3 are operated simultaneously.

Battery Connector Handle with Long Grip

*Only for on-truck charger

The charger plug with long grip and the angled charging port support easy connection.



Management

Battery Data Logging

*Only with battery protecting function and JIS-compliant battery

This provides the useful data such as battery charge status for improving battery maintenance and charging operations. Data can be output via QR code.



The following data are recorded by month, up to one year.

Number of days in operation	Key-on hours
Fluid-level warning time	Charge status

Telematics L_Site

The state of trucks operation, battery status, trucks collision information, and other data can be viewed on a computer or tablet. This can be used for improvements of worksite such as safety management, enhancement of productivity, and cost reductions.