

FD30H

ENGINE POWERED FORKLIFT

H - SERIES 3.0T



HIGH PERFORMANCE EQUIPMENT...
...BACKED BY QUALITY TMHIN SERVICE



Unibody Frame



Backward Visibility



Protected Tail Lamp



Return to Neutral Function



User friendly Instrument Panel



Small Steering Wheel

PERFORMANCE

LOAD HANDLING CAPABILITY



Stable while handling maximum capacity load

FASTER HEAT DISSIPATION



Wide ventilation for faster heat dissipation

NO OIL LEAKS



High quality O-Rings & Seals

PARKING BRAKE LEVER



Parking Brake Lever with Interlock for safety



Optimized lifting and lowering speeds for high intensity operation



Aluminium Radiator for efficient heat transfer



Properly sealed hydraulic tank cover to avoid contamination



**Service by
Toyota Qualified Engineers**



**Preventive Maintenance
(Super Saver Kit)**



Genuine Oils & Lubes

	SN	DESCRIPTION	UNIT	DETAILS
SPECIFICATION	1	Model FD30H	Ton	3.0
	2	Load Capacity (without side shift / with side shift)	kg	2650/2420
	3	Load Center	mm	500
	4	Power Type		Diesel
	5	Control Type		Rider Seat
	6	Tyre (Front / Rear) Pneumatic Shaped cushion		PSC / PSC
DIMENSION	7	Max. Height of Fork	I	mm 4500
	8	Mast Tilting Angle (F/R)	deg.	6 / 6
	9	Fork Distance (Outside)	B	mm 1150
	10	Total Width	A	mm 1225
	11	Overhead Guard Height	V	mm 2170
	12	Min. Turning Radius	G	mm 2670
	13	Mast Extended Height	H	mm 5520
	14	Lowered Mast Height		mm 2100
	15	Free Lift		mm 1500
	16	Front Load Distance	O	mm 470
	17	Total Length	R	mm 3915
PERFORMANCE	18	Travel Speed (with / without load)	km/h	19/20
	19	Lift Speed (with / without load)	mm/s	450/540
	20	Lowering Speed (with / without load)	mm/s	460/500
	21	Service Weight	kg	4530
	22	Max. Gradeability		20%
	23	Tyre Number (Front/Rear)		2/2
	24	Tyre Front		28X9-15
	25	Tyre Rear		6.5-10
	26	Wheelbase	P	mm 1700
	27	Thread (Front/Rear)	C/F	mm 1000 / 985
	28	Ground Clearance Mast	m1	mm 110
	29	Ground Clearance Center of wheelbase	m2	mm 210
	30	Brake Service Foot		Hydraulic
	31	Brake Parking		Hand
POWER	32	Engine Rated Power / rpm	kw/rpm	36.8 / 2650
	33	Engine Number of cylinders		4
	34	Engine Piston Displacement	cc	2670
	35	Transmission Type		Automatic
	36	Service Pressure	Mpa	18.14

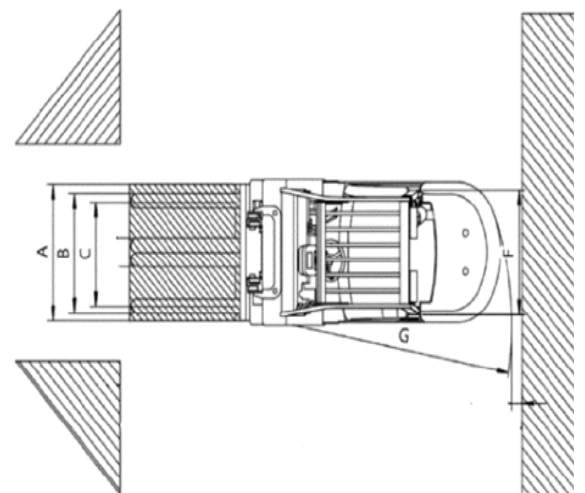
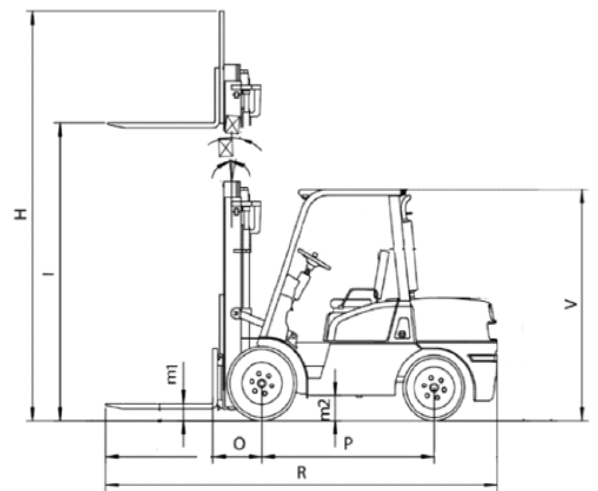

Toyota Material Handling India Pvt. Ltd.

Head Office: 43 Milestone NH-8, Delhi-Jaipur Highway, Gurgaon – 122004, Haryana

Tel: 0124-3877100, E-mail: info.sales@tmhin.toyota-industries.com, Web: www.toyotamaterialhandlingindia.com

For Enquiries

Bangalore M: +91-9845003971

Hyderabad M: +91-9741426287

Chennai M: +91-9600986222

Coimbatore M: +91-9600954666

Delhi M: +91-9810997357

Kolkata M: +91-9717725926

Punjab M: +91-9958010307

Mumbai M: +91-9004415045

Pune M: +91-7738694001

Ahmedabad M: +91-8600239978