

Pedestrian stacker truck 1.2- 2.0 ton



BT staxio

P-series

SPE120L

SPE140L

SPE160L

SPE200L



Pedestrian stacker with elevating support arms

| Specifications | | | | SPE120L | SPE140L | SPE160L | SPE200L | |
|------------------|--|---|--------------------------------|---------------------|-------------------------------|---------------------|---------------------|--------------|
| Identification | 1.1 | Manufacturer | | Toyota | Toyota | Toyota | Toyota | |
| | 1.2 | Model | | SPE120L | SPE140L | SPE160L | SPE200L | |
| | 1.3 | Drive | | Electric | Electric | Electric | Electric | |
| | 1.4 | Operator type | | Stand on/pedestrian | Stand on/pedestrian | Stand on/pedestrian | Stand on/pedestrian | |
| | 1.5 | Load capacity/rated load | Q | kg | 1200 | 1400 | 1600 | 2000 |
| | | Support arm capacity | Q | kg | 2000 | 2000 | 2000 | 2000 |
| | 1.6 | Load center | c | mm | 600 | 600 | 600 | 600 |
| | 1.8 | Load distance, centre of support arm wheel to face of forks | | | | | | |
| | | raised support arms | x | mm | 694 | 661 | 661 | 644 |
| | lowered support arms | x | mm | 725 | 692 | 692 | 675 | |
| 1.9 | Wheelbase | | | | | | | |
| | raised support arms | y | mm | 1408 | 1408 | 1408 | 1408 | |
| | lowered support arms | y | mm | 1439 | 1439 | 1439 | 1439 | |
| Weight | 2.1 | Service weight incl. battery | | kg | 1349 | 1489 | 1489 | 1691 |
| | 2.2 | Axle load, with load, drive/castor/fork wheel | | kg | 680/249/1620 | 820/143/1926 | 870/94/2125 | 680/384/2627 |
| | 2.3 | Axle load, without load, drive/castor/fork wheel | | kg | 400/496/453 | 510/450/529 | 510/529/450 | 400/676/615 |
| Wheels | 3.1 | Drive/castor/fork wheel | | | Friction/Vulkolan®/Vulkollan® | | | |
| | 3.2 | Wheel size, front | | mm | Ø 230 | Ø 230 | Ø 230 | Ø 230 |
| | 3.3 | Wheel size, rear | | mm | Ø 85 | Ø 85 | Ø 85 | Ø 85 |
| | 3.4 | Additional wheel size | | mm | Ø 125 | Ø 125 | Ø 125 | Ø 125 |
| | 3.5 | Wheels, number front/rear (x = driven wheels) | | | 1x+2/2 or 4 | 1x+2/2 or 4 | 1x+2/2 or 4 | 1x+2/2 or 4 |
| | 3.6 | Track width, front | b ₁₀ | mm | 585 | 585 | 585 | 585 |
| | 3.7 | Track width, rear | b ₁₁ | mm | 390 | 390 | 390 | 390 |
| Dimensions | 4.2 | Height, mast lowered | h ₁ | mm | 1995 | 1946 | 1946 | 1946 |
| | 4.3 | Free lift | h ₂ | mm | 1556 | 1478 | 1478 | 1378 |
| | 4.4 | Lift | h ₃ | mm | 4060 | 4060 | 4060 | 3960 |
| | | Lift height | h ₂₃ | mm | 4150 | 4150 | 4150 | 4050 |
| | 4.5 | Height, mast extended | h ₄ | mm | 4657 | 4668 | 4668 | 4668 |
| | 4.6 | Initial Lift | h ₅ | mm | 120 | 120 | 120 | 120 |
| | 4.8 | Stand height | h ₇ | mm | 190 | 190 | 190 | 190 |
| | 4.9 | Height of tiller in drive position, min./max. | | | | | | |
| | | highest setting | h ₁₄ | mm | 1201/1413 | 1201/1413 | 1201/1413 | 1201/1413 |
| | | lowest setting | h ₁₄ | mm | 1101/1313 | 1101/1313 | 1101/1313 | 1101/1313 |
| | 4.15 | Height, fork lowered | h ₁₃ | mm | 90 | 90 | 90 | 90 |
| | 4.19 | Overall length | | | | | | |
| | | platform up | l ₁ | mm | 2085 | 2106 | 2106 | 2129 |
| | | platform down | l ₁ | mm | 2532 | 2565 | 2565 | 2577 |
| | 4.20 | Length to face of forks | | | | | | |
| | | platform up | l ₂ | mm | 935 | 956 | 956 | 979 |
| | | platform down | l ₂ | mm | 1382 | 1415 | 1415 | 1427 |
| | 4.21 | Overall width | b ₁ /b ₂ | mm | 790/— | 790/— | 790/— | 850/— |
| | 4.22 | Fork dimensions | s/e/l | mm | 70/180/1150 | 70/180/1150 | 70/180/1150 | 70/185/1150 |
| | 4.25 | Width over forks | b ₅ | mm | 570 | 570 | 570 | 575 |
| 4.32 | Ground clearance, center of wheelbase | m ₂ | mm | 19,5 | 19,5 | 19,5 | 19,5 | |
| 4.33 | Aisle width for pallets 1000x1200 crossways | | | | | | | |
| | platform up | A _{st} | mm | 2619 | 2639 | 2639 | 2650 | |
| | platform down | A _{st} | mm | 3068 | 3088 | 3088 | 3099 | |
| 4.34 | Aisle width for pallets 800x1200 lengthways | | | | | | | |
| | platform up | A _{st} | mm | 2510 | 2536 | 2536 | 2550 | |
| | platform down | A _{st} | mm | 2959 | 2985 | 2985 | 2999 | |
| 4.35 | Turning radius | | | | | | | |
| | platform up | W _a | mm | 1665 | 1665 | 1665 | 1665 | |
| | platform down | W _a | mm | 2114 | 2114 | 2114 | 2114 | |
| Performance data | 5.1 | Travel speed, with/without load | | | | | | |
| | | 6 km/h version | km/h | 6,0/6,0 | 6,0/6,0 | 6,0/6,0 | 6,0/6,0 | |
| | | 8 km/h version | km/h | 7,0/8,0 | 7,0/8,0 | 7,0/8,0 | — | |
| | | 10 km/h version | km/h | — | 9,0/10,0 | 9,0/10,0 | — | |
| | 5.2 | Lift speed, with/without load | | | | | | |
| | | | m/s | 0,20/0,36 | 0,17/0,33 | 0,15/0,31 | 0,13/0,24 | |
| 5.3 | Lowering speed, with/without load | | | | | | | |
| | | m/s | 0,45/0,45 | 0,45/0,45 | 0,45/0,45 | 0,38/0,45 | | |
| 5.8 | Max. gradeability, with/without load | | % | 8/12 | 8/12 | 8/12 | 8/12 | |
| 5.9 | Acceleration time (over 10 m) | | s | 5,2 | 5,3 | 5,5 | 6,6 | |
| 5.10 | Service brake | | | Electromagnetic | Electromagnetic | Electromagnetic | Electromagnetic | |
| Electric motor | 6.1 | Drive motor rating (S2 60min) | | | | | | |
| | | 6 km/h version | kW | 1,8 | 1,8 | 1,8 | 1,8 | |
| | | 8 km/h version | kW | 1,8 | 1,8 | 1,8 | — | |
| | | 10 km/h version | kW | — | 2,5 | 2,5 | — | |
| | 6.2 | Lift motor rating (S3 15%) | | | | | | |
| | | | kW | 3 | 3 | 3 | 3 | |
| 6.4 | Battery voltage, nominal capacity K _s | | V/Ah | 24/300 | 24/300 | 24/300 | 24/300 | |
| 6.5 | Battery weight | | kg | 195-270 | 195-270 | 195-270 | 195-270 | |
| 6.6 | Energy consumption acc to VDI cycle | | kWh/h | 1,04 | 1,06 | 1,07 | 1,06 | |
| Others | 8.1 | Type of drive control | | | Variable AC | Variable AC | Variable AC | |
| | 8.4 | Sound level at the driver's ear according to EN 12 053 | | dB (A) | 66 | 66 | 66 | |

1) Measured according to company standard.

Data is based on standard truck and small battery.

All data are based on table configuration. Other configurations may give other values.

Truck performance and dimensions are nominal and subject to tolerances.

Toyota Material Handling Manufacturing Sweden AB products and specifications are subject to change without notice.

Battery dependent dimensions

| Dimensions | | Battery | | SPE120L | | | | SPE140L | | | | SPE160L | | | | SPE200L | | | |
|------------|---|----------|------|----------|---------|----------|---------|----------|---------|----------|---------|----------|---------|----------|---------|----------|---------|----------|---------|
| | | | | Lift out | | Sideways | | Lift out | | Sideways | | Lift out | | Sideways | | Lift out | | Sideways | |
| | | | | S | L* | S | L* | S | L* | S | L* | S | L* | S | L* | S | L* | S | L* |
| 1.9 | Wheelbase | | | | | | | | | | | | | | | | | | |
| | raised support arms | y | mm | 1408 | 1505 | 1408 | 1505 | 1408 | 1505 | 1408 | 1505 | 1408 | 1505 | 1408 | 1505 | 1408 | 1505 | 1408 | 1505 |
| | lowered support arms | y | mm | 1439 | 1536 | 1436 | 1536 | 1439 | 1536 | 1439 | 1536 | 1439 | 1536 | 1439 | 1536 | 1439 | 1536 | 1439 | 1536 |
| 4.19 | Overall length | | | | | | | | | | | | | | | | | | |
| | platform up | l_1 | mm | 2085 | 2181 | 2085 | 2181 | 2106 | 2203 | 2106 | 2203 | 2106 | 2203 | 2106 | 2203 | 2129 | 2226 | 2129 | 2226 |
| | platform down | l_1 | mm | 2532 | 2631 | 2532 | 2631 | 2565 | 2665 | 2565 | 2665 | 2565 | 2665 | 2565 | 2665 | 2577 | 2674 | 2577 | 2674 |
| 4.20 | Length to face of forks | | | | | | | | | | | | | | | | | | |
| | platform up | l_2 | mm | 935 | 1031 | 935 | 1031 | 956 | 1053 | 956 | 1053 | 956 | 1053 | 956 | 1053 | 979 | 1076 | 979 | 1076 |
| | platform down | l_2 | mm | 1382 | 1481 | 1382 | 1481 | 1415 | 1515 | 1415 | 1515 | 1415 | 1515 | 1415 | 1515 | 1427 | 1524 | 1427 | 1524 |
| 4.33 | Aisle width for pallets 1000x1200 crossways | | | | | | | | | | | | | | | | | | |
| | platform up | A_{st} | mm | 2619 | 2715 | 2619 | 2715 | 2639 | 2735 | 2639 | 2735 | 2639 | 2735 | 2639 | 2735 | 2650 | 2746 | 2650 | 2746 |
| | platform down | A_{st} | mm | 3068 | 3165 | 3068 | 3165 | 3088 | 3185 | 3088 | 3185 | 3088 | 3185 | 3088 | 3185 | 3099 | 3196 | 3099 | 3196 |
| 4.34 | Aisle width for pallets 800x1200 lengthways | | | | | | | | | | | | | | | | | | |
| | platform up | A_{st} | mm | 2510 | 2606 | 2510 | 2606 | 2536 | 2632 | 2536 | 2632 | 2536 | 2632 | 2536 | 2632 | 2550 | 2646 | 2550 | 2646 |
| | platform down | A_{st} | mm | 2959 | 3056 | 2959 | 3056 | 2985 | 3082 | 2985 | 3082 | 2985 | 3082 | 2985 | 3082 | 2999 | 3096 | 2999 | 3096 |
| 4.35 | Turning radius | | | | | | | | | | | | | | | | | | |
| | platform up | W_a | mm | 1665 | 1761 | 1665 | 1761 | 1665 | 1761 | 1665 | 1761 | 1665 | 1761 | 1665 | 1761 | 1665 | 1761 | 1665 | 1761 |
| | platform down | W_a | mm | 2114 | 2211 | 2114 | 2211 | 2114 | 2211 | 2114 | 2211 | 2114 | 2211 | 2114 | 2211 | 2114 | 2211 | 2114 | 2211 |
| 6.4 | Battery voltage, nominal capacity K_s | | V/Ah | 24/300 | 24/500 | 24/300 | 24/500 | 24/300 | 24/500 | 24/300 | 24/500 | 24/300 | 24/500 | 24/300 | 24/500 | 24/300 | 24/500 | 24/300 | 24/500 |
| 6.5 | Battery weight, min.—max. | | kg | 195-310 | 345-405 | 195-300 | 345-405 | 195-310 | 345-405 | 195-310 | 345-405 | 195-310 | 345-405 | 195-310 | 345-405 | 195-310 | 345-405 | 195-310 | 345-405 |

* DIN battery will give same truck dimensions as for the large battery

Mast dimensions

| Mast | | | Duplex Tele Panoramic View | | | | | Duplex HiLo | | | | | Triplex HiLo | | | | | | | | | | |
|---------|----------|-----------------------------------|----------------------------|------|------|------|------|-------------|------|------|------|------|--------------|------|------|------|------|------|------|------|------|------|------|
| SPE120L | h_{23} | Lift height ($h_{13}+h_3$) | mm | 2350 | 2800 | 3300 | 3700 | 4150 | 1950 | 2350 | 2500 | 2800 | 3300 | 3700 | 4150 | 3300 | 3700 | 3950 | 4150 | 4500 | 4800 | — | — |
| | h_3 | Lift | mm | 2260 | 2710 | 3210 | 3610 | 4060 | 1860 | 2260 | 2410 | 2710 | 3210 | 3610 | 4060 | 3210 | 3610 | 3860 | 4060 | 4410 | 4710 | — | — |
| | h_1 | Height, mast lowered | mm | 1710 | 1935 | 2185 | 2385 | 2610 | 1510 | 1710 | 1785 | 1935 | 2185 | 2385 | 2610 | 1712 | 1845 | 1928 | 1995 | 2112 | 2212 | — | — |
| | h_2 | Free lift, ground to top of forks | mm | 172 | 172 | 172 | 172 | 172 | 1082 | 1282 | 1356 | 1506 | 1756 | 1956 | 2182 | 1274 | 1406 | 1490 | 1556 | 1674 | 1774 | — | — |
| | h_4 | Height, mast extended | mm | 2827 | 3277 | 3777 | 4177 | 4627 | 2468 | 2868 | 3018 | 3318 | 3818 | 4218 | 4668 | 3808 | 4207 | 4456 | 4657 | 5008 | 5308 | — | — |
| SPE140L | h_{23} | Lift height ($h_{13}+h_3$) | mm | 2350 | 2800 | 3300 | 3700 | 4150 | — | 2350 | 2500 | 2800 | 3300 | 3700 | 4150 | 3300 | 3700 | 3950 | 4150 | 4500 | 4800 | 5400 | — |
| | h_3 | Lift | mm | 2260 | 2710 | 3210 | 3610 | 4060 | — | 2260 | 2410 | 2710 | 3210 | 3610 | 4060 | 3210 | 3610 | 3860 | 4060 | 4410 | 4710 | 5310 | — |
| | h_1 | Height, mast lowered | mm | 1737 | 1962 | 2212 | 2412 | 2637 | — | 1736 | 1811 | 1961 | 2211 | 2411 | 2636 | 1662 | 1796 | 1879 | 1946 | 2062 | 2162 | 2362 | — |
| | h_2 | Free lift, ground to top of forks | mm | — | — | — | — | — | — | 1256 | 1332 | 1482 | 1732 | 1932 | 2156 | 1194 | 1328 | 1410 | 1478 | 1594 | 1694 | 1894 | — |
| | h_4 | Height, mast extended | mm | 2892 | 3342 | 3842 | 4242 | 4692 | — | 2891 | 3041 | 3341 | 3841 | 4241 | 4691 | 3816 | 4218 | 4467 | 4668 | 5016 | 5316 | 5916 | — |
| SPE160L | h_{23} | Lift height ($h_{13}+h_3$) | mm | 2350 | 2800 | 3300 | 3700 | 4150 | 1950 | 2350 | 2500 | 2800 | 3300 | 3700 | 4150 | 3300 | 3700 | 3950 | 4150 | 4500 | 4800 | 5400 | 6000 |
| | h_3 | Lift | mm | 2260 | 2710 | 3210 | 3610 | 4060 | 1860 | 2260 | 2410 | 2710 | 3210 | 3610 | 4060 | 3210 | 3610 | 3860 | 4060 | 4410 | 4710 | 5310 | 5910 |
| | h_1 | Height, mast lowered | mm | 1737 | 1962 | 2212 | 2412 | 2637 | 1536 | 1736 | 1811 | 1961 | 2211 | 2411 | 2636 | 1662 | 1796 | 1879 | 1946 | 2062 | 2162 | 2362 | 2562 |
| | h_2 | Free lift, ground to top of forks | mm | — | — | — | — | — | 1056 | 1256 | 1332 | 1482 | 1732 | 1932 | 2156 | 1194 | 1328 | 1410 | 1478 | 1594 | 1694 | 1894 | 2096 |
| | h_4 | Height, mast extended | mm | 2892 | 3342 | 3842 | 4242 | 4692 | 2491 | 2891 | 3041 | 3341 | 3841 | 4241 | 4691 | 3816 | 4218 | 4467 | 4668 | 5016 | 5316 | 5916 | 6520 |

| Mast | | | Duplex Tele Panoramic View | | | | | Duplex HiLo | | | | | Triplex HiLo | | | | | |
|---------|----------|-----------------------------------|----------------------------|------|------|------|------|-------------|------|------|------|------|--------------|------|------|------|------|------|
| SPE200L | h_{23} | Lift height ($h_{13}+h_3$) | mm | 2150 | 2600 | 3100 | 3500 | 3950 | 2150 | 2300 | 2600 | 3100 | 3500 | 3950 | 3200 | 3600 | 3850 | 4050 |
| | h_3 | Lift | mm | 2060 | 2510 | 3010 | 3410 | 3860 | 2060 | 2210 | 2510 | 3010 | 3410 | 3860 | 3110 | 3510 | 3760 | 3960 |
| | h_1 | Height, mast lowered | mm | 1737 | 1962 | 2212 | 2412 | 2637 | 1737 | 1812 | 1962 | 2212 | 2412 | 2637 | 1662 | 1796 | 1879 | 1946 |
| | h_2 | Free lift, ground to top of forks | mm | — | — | — | — | — | 1156 | 1232 | 1382 | 1632 | 1832 | 2056 | 1094 | 1228 | 1310 | 1378 |
| | h_4 | Height, mast extended | mm | 2792 | 3242 | 3742 | 4142 | 4592 | 2792 | 2942 | 3242 | 3742 | 4142 | 4592 | 3816 | 4218 | 4467 | 4668 |

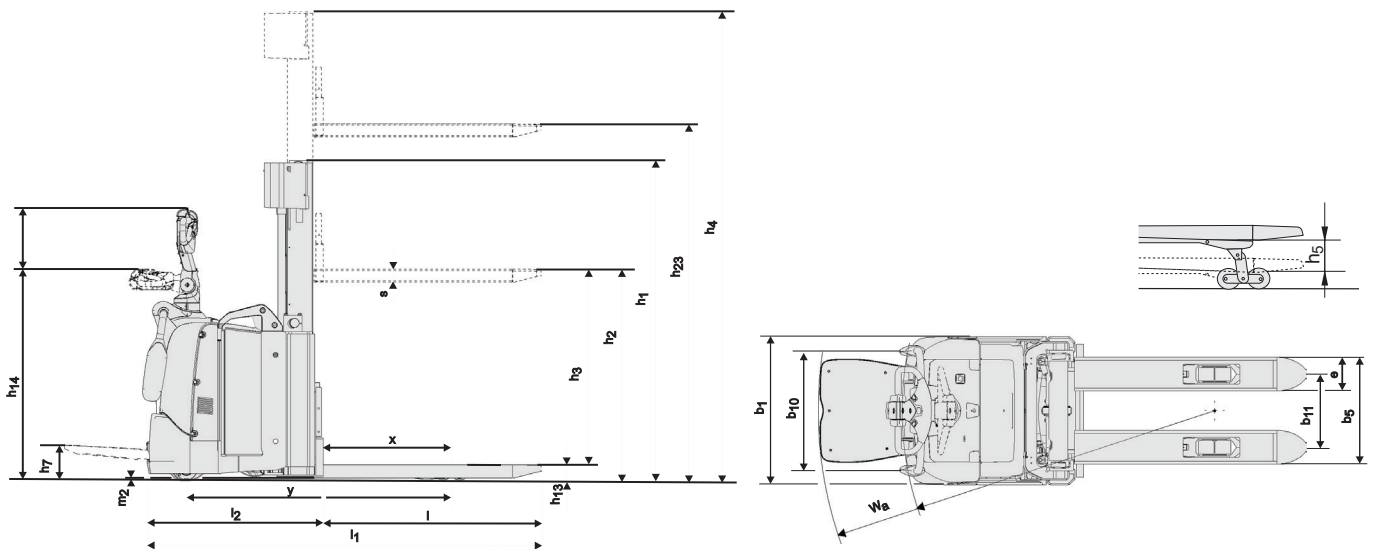

Truck features:

- BT Powertrak traction system
- Optimized Truck Performance
- Fingertip controls
- Electronic braking system
- Electronic speed control
- Operator safety
- Storage compartments
- Automatic switch-off
- Programmable performance
- Easy access for maintenance
- Sensilift
- Toyota I_site: truck fleet management system (option)
- Hydraulic oil for low temperatures (option)

