

# Pedestrian stacker truck 1.0 ton

## BT staxio

*W-series*

HWE100

HWE100S

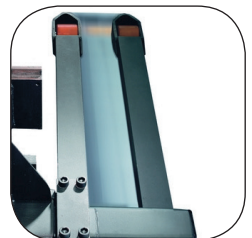

# Pedestrian stacker truck

Specification for stacker trucks					HWE100	HWE100S
Identification	1.1	Manufacturer			Toyota	Toyota
	1.2	Model			HWE100	HWE100S
	1.3	Drive			Electric	Electric
	1.4	Operator type			Pedestrian	Pedestrian
	1.5	Load capacity/rated load	Q	kg	1000	1000
	1.6	Load centre	c	mm	600	600
	1.8	Load distance, centre of support arm wheel to face of forks	x	mm	805 *)	800
	1.9	Wheelbase	y	mm	1178 *)	1210
Weight	2.1	Service weight		kg	467	560
	2.2	Axle load, with load, drive/castor/fork wheel		kg	353/151/963	580/—/515
	2.3	Axle load, without load, drive/castor/fork wheel		kg	230/123/114	400/—/80
Wheels	3.1	Drive/castor/fork wheel			PU/PU/PU	PU/—/PU
	3.2	Wheel size, front	Ø x width	mm	250x60	250x60
	3.3	Wheel size, rear	Ø x width	mm	85x77	85x77
	3.4	Additional wheels (dimensions)	Ø x width	mm	100x40	—
	3.5	Wheels, number front/rear (x = driven wheels)			1x-2/2	1x/2
	3.6	Track width, front	b <sub>10</sub>	mm	506	506
	3.7	Track width, rear	b <sub>11</sub>	mm	364 *)	1000—1400
Dimensions	4.2	Height, mast lowered	h <sub>1</sub>	mm	1890	1890
	4.4	Lift	h <sub>3</sub>	mm	1495	1500
		Lift height	h <sub>23</sub>	mm	1580	1540
	4.5	Height, mast extended	h <sub>4</sub>	mm	2040	2040
	4.9	Height of tiller in drive position, min./max.	h <sub>14</sub>	mm	858/1222	858/1222
	4.15	Height, fork lowered	h <sub>13</sub>	mm	85	50
	4.19	Overall length	l <sub>1</sub>	mm	1680	1722
	4.20	Length to face of forks	l <sub>2</sub>	mm	530	572
	4.21	Overall width	b <sub>1</sub> /b <sub>2</sub>	mm	700	700/1100—1500
	4.22	Fork dimensions	s/e/l	mm	60/180/1150 *)	40/100/1150
	4.25	Width over forks	b <sub>5</sub>	mm	550 *)	250—800
	4.26	Distance between support arms	b <sub>4</sub>	mm	—	900—1300
	4.27	Support arm width	b <sub>14</sub>	mm	—	100
	4.31	Ground clearance, below mast	m <sub>1</sub>	mm	49	49
	4.32	Ground clearance, centre of wheelbase	m <sub>1</sub>	mm	26	26
4.34	Aisle width for pallets 800x1200 lengthways	A <sub>st</sub>	mm	2100	2130	
4.35	Turning radius	W <sub>e</sub>	mm	1340	1365	
Performance data	5.1	Travel speed, with/without load		km/h	4,5/5,5	4,5/5,5
	5.2	Lift speed, with/without load		m/s	0,12/0,21	0,10/0,19
	5.3	Lowering speed, with/without load		m/s	0,15/0,14	0,15/0,14
	5.8	Max. gradeability, with/without load		%	6/10 <sup>1)</sup>	6/10 <sup>1)</sup>
	5.10	Service brake			Electromagnetic	Electromagnetic
Electric motor	6.1	Drive motor rating S2 60 min		kW	0,7	0,7
	6.2	Lift motor rating at S3 5%		kW	1,2	1,2
	6.4	Battery voltage/nominal capacity K <sub>5</sub>		V/Ah	2x12/63	2x12/63
	6.5	Battery weight		kg	2x23	2x23
	6.6	Energy consumption acc. to VDI cycle (with h <sub>23</sub> = 1580mm / with h <sub>23</sub> = 2000mm)		kWh/h	0,62/0,76	
	Others	8.1	Type of drive control			Variable AC
8.4		Sound level at the driver's ear according to EN 12 053		dB(A)	66	66

1) Measured according to company standard.

\*) Further alternatives are available and will produce other values.

All data are based on table configuration. Other configurations may give other values.

Truck performance and dimensions are nominal and subject to tolerances.

Toyota Material Handling Manufacturing Sweden AB products and specifications are subject to change without notice.

# Mast dimensions

				HWE100			HWE100S		
Height, mast lowered	$h_1$	mm	1635	1890	2310	1635	1890	2310	
Lift movement	$h_3$	mm	1095	1495	1915	1100	1500	1920	
Height, mast extended	$h_4$	mm	—	—	—	1640	2040	2460	
Lift height ( $h_{13}+h_3$ )	$h_{23}$	mm	1180	1580	2000	1140	1540	1960	

## HWE100

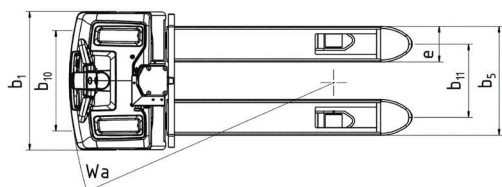
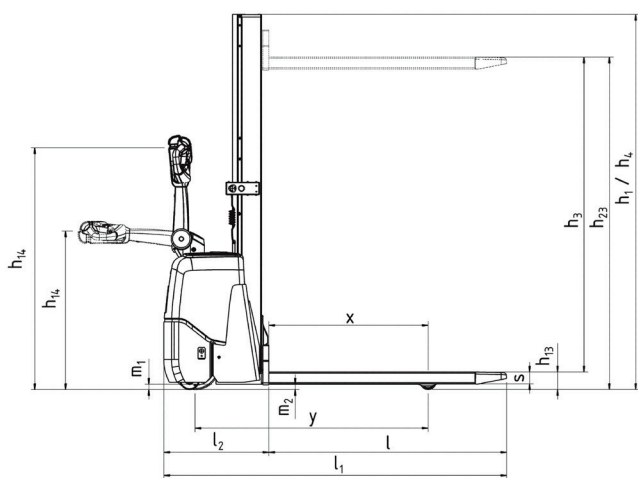

## HWE100S

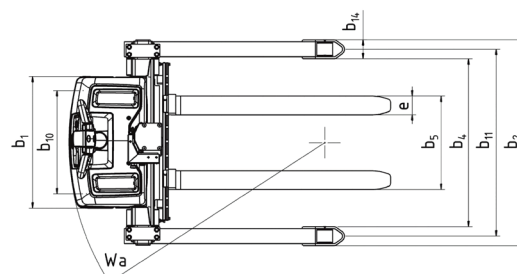
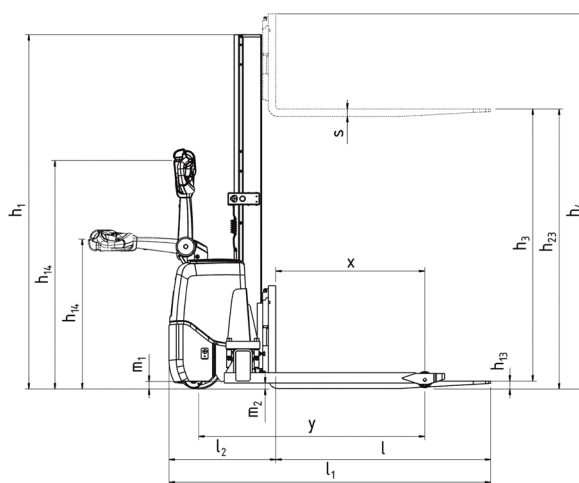

---

## Truck features:

- Compact and easy to manoeuvre
- Maintenance free batteries
- Built in charger
- Click-2-Creep
- Individual parameter settings
- Maintenance-free AC drive motor
- Access control with pin code
- Compatible with fleet management tool I\_Site

