

Order picking truck 2.5 ton

BT optio

L-series

OSE250/P

T-mote remote drive



Order picking truck

Truck specifications					OSE250 T-mote	OSE250P T-mote
Identification	1.1	Manufacturer			Toyota	Toyota
	1.2	Model			OSE250 T-mote	OSE250P T-mote
	1.3	Drive			Electric	Electric
	1.4	Operator type			Stand on	Stand on
	1.5	Load capacity/rated load	Q	kg	2500	2500
	1.6	Load centre	c	mm	1200	1200
	1.8	Load distance, back of fork to bogie wheel centre, raised/lowered support arms	x	mm	1776/1866	1776/1866
	1.9	Wheelbase, raised/lowered support arms	y	mm	2884/2970	2884/2970
	Weight	2.1	Service weight without battery, short/long chassis		kg	1201/1225
2.2		Axle load, with load, drive/castor/fork wheels short chassis long chassis		kg	780/836/943	780/836/943
				kg	894/800/2243	894/800/2243
2.3		Axle load, without load, drive/castor/fork wheels short chassis long chassis		kg	480/270/250	480/270/250
				kg	500/300/270	500/300/270
Wheels		3.1	Drive/castor/fork wheels			Vulkollan
	3.2	Wheel size, front	Ø x width	mm	250x92	250x92
	3.3	Wheel size, rear	Ø x width	mm	85x75	85x75
	3.4	Additional wheels (dimensions)	Ø x width	mm	150x75	150x75
	3.5	Wheels, number front/rear (x = driven wheels)		mm	1x+1/4	1x+1/4
Dimensions	4.2.1	Overall height	h_{15}	mm	1300	1300/2260
	4.4	Lift Lift height	h_3	mm	150	150
			h_{23}	mm	235	235
	4.8	Stand height, min./max.	h_7	mm	138	138 / 980
	4.15	Height, fork lowered	h_{13}	mm	85	85
	4.19	Overall length, short/long chassis	l_1	mm	3764/3850	3764/3850
	4.20	Length to face of forks, short/long chassis	l_2	mm	1414/1500	1414/1500
	4.21	Overall width	b_1	mm	790	790
	4.22	Fork dimensions	s/e/l	mm	50/180/2350	50/180/2350
	4.25	Width over forks	b_5	mm	450 – 685	450 – 685
	4.31	Ground clearance	m_1	mm	40	40
	4.34	Aisle width for pallets 2x(800x1200) lengthways	A_{st}	mm	4132/4218	4132/4218
	4.35	Turning radius, short/long chassis	W_a	mm	3191/3277	3191/3277
	4.44	Clear width driver compartment entrance	l_{24}	mm	450	450
Performance data	5.1	Travel speed, with/without load		km/h	8,0/12,0	8,0/12,0
	5.1.1	Travel speed with remote drive		km/h	4	4
	5.2	Lift speed, with/without load		m/s	0,07/0,09	0,07/0,09
	5.3	Lowering speed, with/without load		m/s	0,06/0,06	0,06/0,06
	5.8	Max. gradeability, with/without load ¹⁾		%	8/13	8/13
	5.10	Service brake			Electromagnetic	Electromagnetic
Electric motor	6.1	Drive motor rating S2 60 min		kW	2,8	2,8
	6.2	Lift motor rating S3 7%		kW	2,0	2,0
	6.4	Battery voltage, nominal capacity K_s		V/Ah	24/310, 620	24/310, 620
	6.5	Battery weight, min./max.		kg	239/501	239/501
	6.6	Energy consumption acc to VDI cycle		kWh/h	0,61	0,61
	Other	8.1	Type of drive control			Powerdrive
8.4		Sound level at the driver's ear according to DIN 12 053		dB(A)	63	63

1) Measured according to company standard.

All data are based on table configuration. Other configurations may give other values.

Truck performance and dimensions are nominal and subject to tolerances.

Toyota Material Handling Manufacturing Sweden AB products and specifications are subject to change without notice.

Dimensional drawings

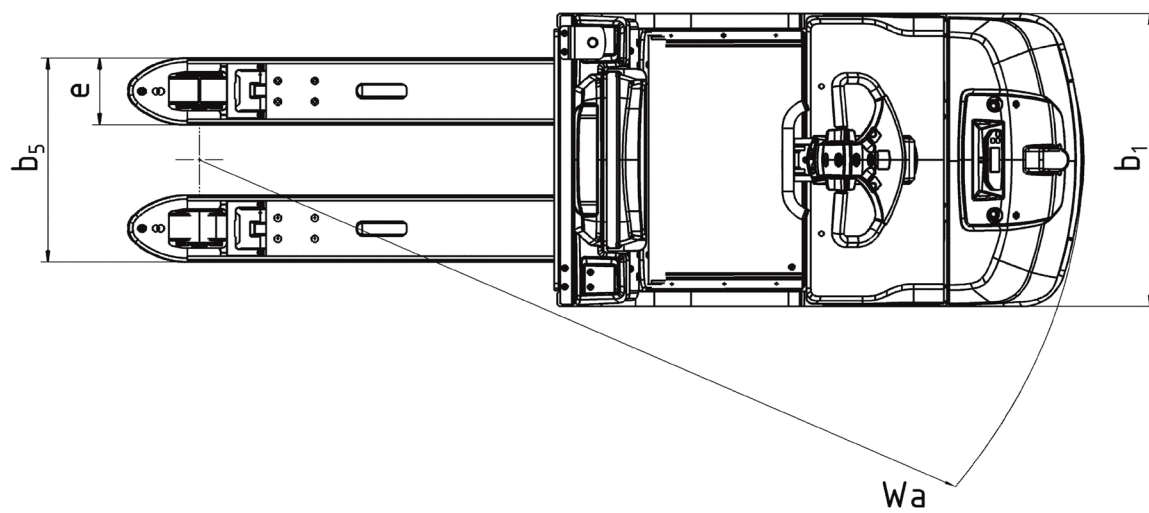
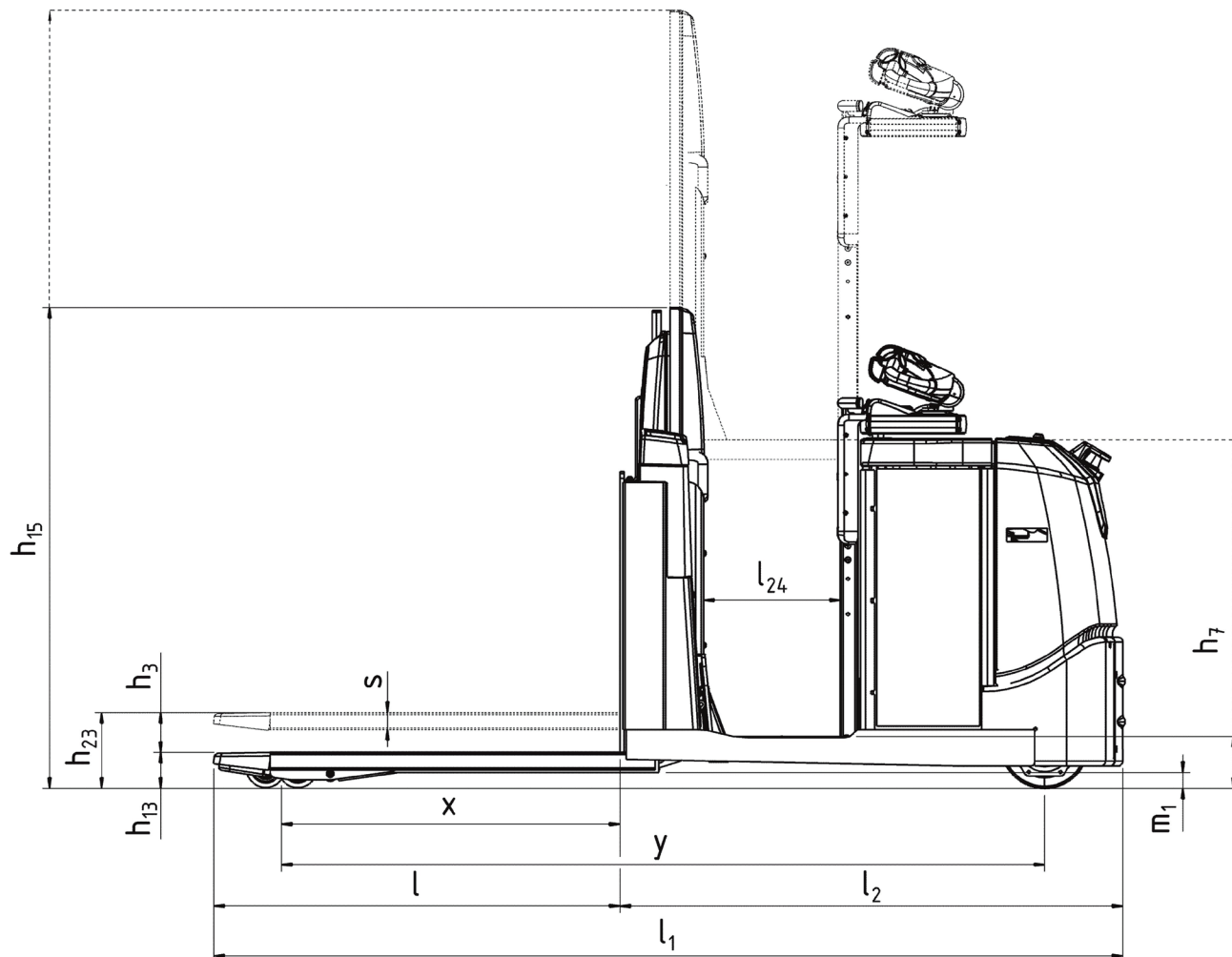

Truck features:

- High performance models
- Low step-in
- Optimized Truck Performance - a collection of features that will guarantee optimum performance & safety at all times
- T-mote, hands-free remote drive feature (incl. scanner, indication lights, information display, & remote control to operate the truck remotely). The T-mote system features adjustable proximity to racking, minor travel path correction and automatic and manual alignment left/right when inside the aisle
- E-man steering concept – easy and ergonomic access to all vital functions via the operation handle
- Adjustable E-man handle (option)

